

HARDWARE

flight case and cabinet components

AERATION DISHES - vers. 02/2014

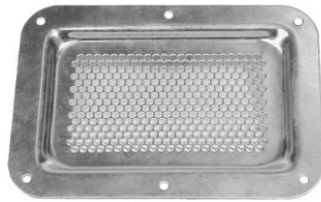
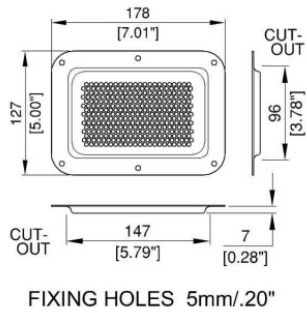

AC7242 - 42N

Large perforated dish - Zinc and black

material: Steel
finish: Zinc
weight: 160 gr.

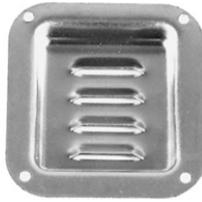
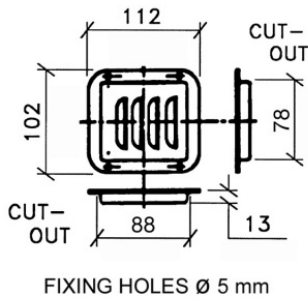

AC7432 - 32N

Square dish punched for louvre - Zinc and black

material: Steel 12/10
finish: Zinc - N = Black
weight: 130 gr

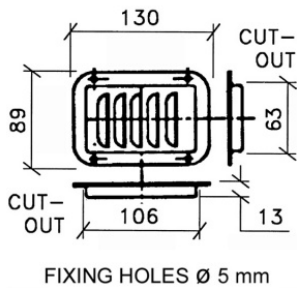

AC7422 - 22N

Dish vertical louvre - Zinc and black

material: Steel 12/10
finish: Zinc - N = Black
weight: 130 gr

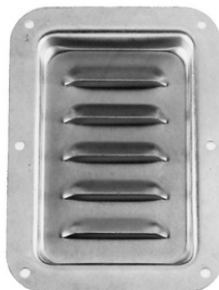
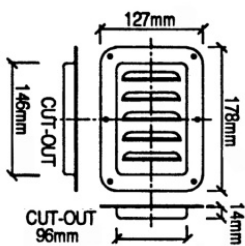

AC7412 - 12N

Large dish vertical louvre - Zinc and black

material: Steel 12/10
finish: Zinc - N = Black
weight: 255 / 300 gr.

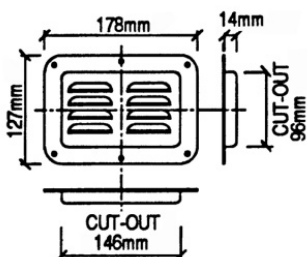

AC7402 - 02N

Large dish horizontal louvre - Zinc and black

material: Steel 15/10
finish: Zinc - N = Black
weight: 300 gr

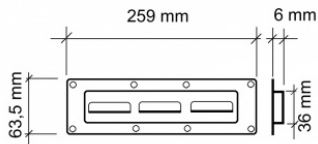

RK2672 - 72N

Slotted vent panel - Zinc and black

material: Steel 12/10
 finish: Zinc - N = Black
 weight: 130 gr

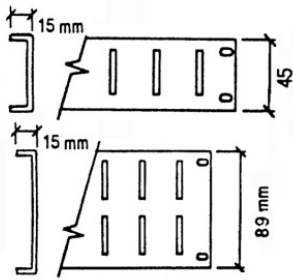

FIXING SLOTS 7.5 x 10 mm

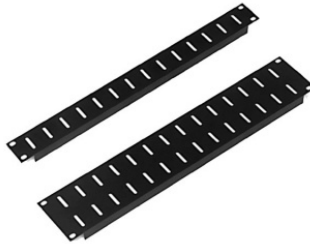

RK2481N - RK2491N

Rack panel vented for rack 19"

material: Aluminium 2 mm
 finish: Anodized black
 weight: 142 / 260 gr.

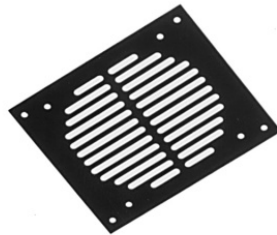
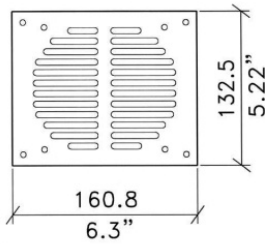

RK2662N

Single fan grille

material: Steel
 finish: Black
 weight: 60 gr

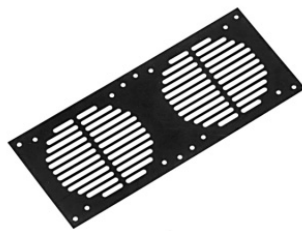
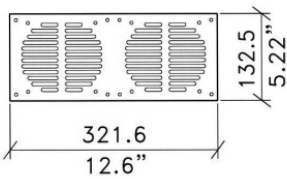

RK2664N

Double fan grille

material: Steel
 finish: Black
 weight: 290 gr

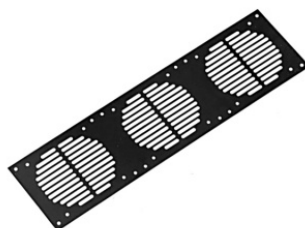
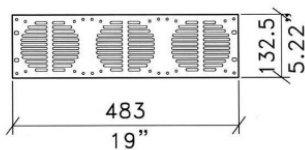

RK2666N

Triple fan grille

material: Steel
 finish: Black
 weight: 500 gr

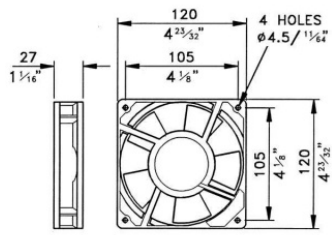

AC7501

Cooling fan

material: Aluminium + Plastic

finish: Black

weight: 350 gr